

CC-5B Series Crushers

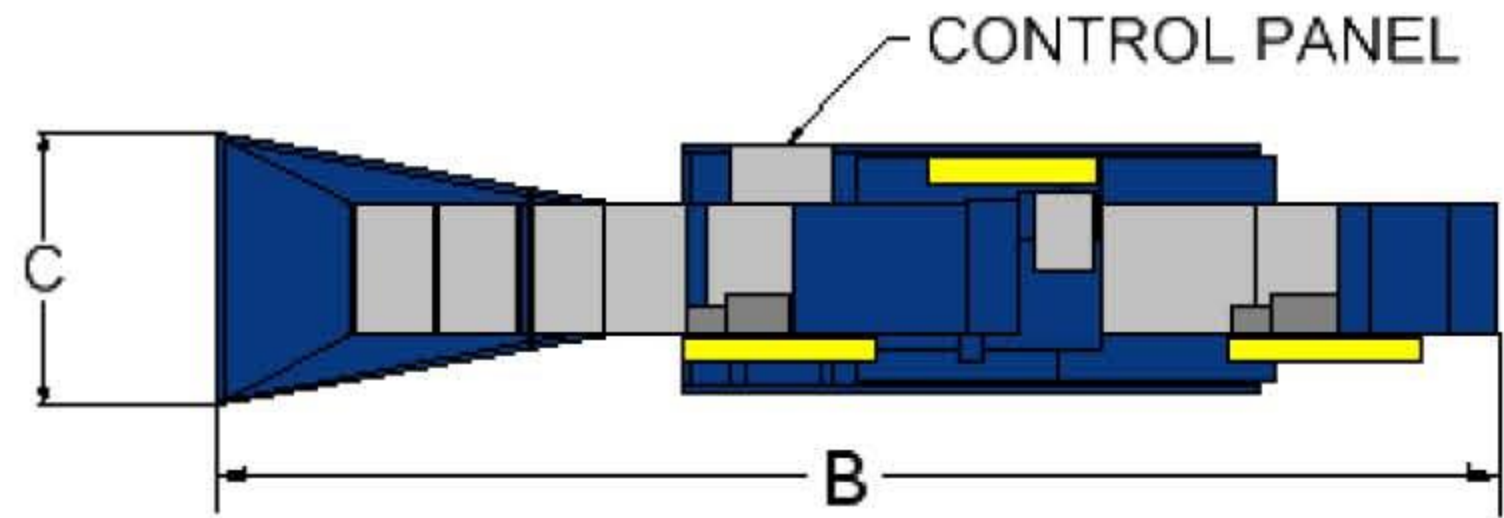
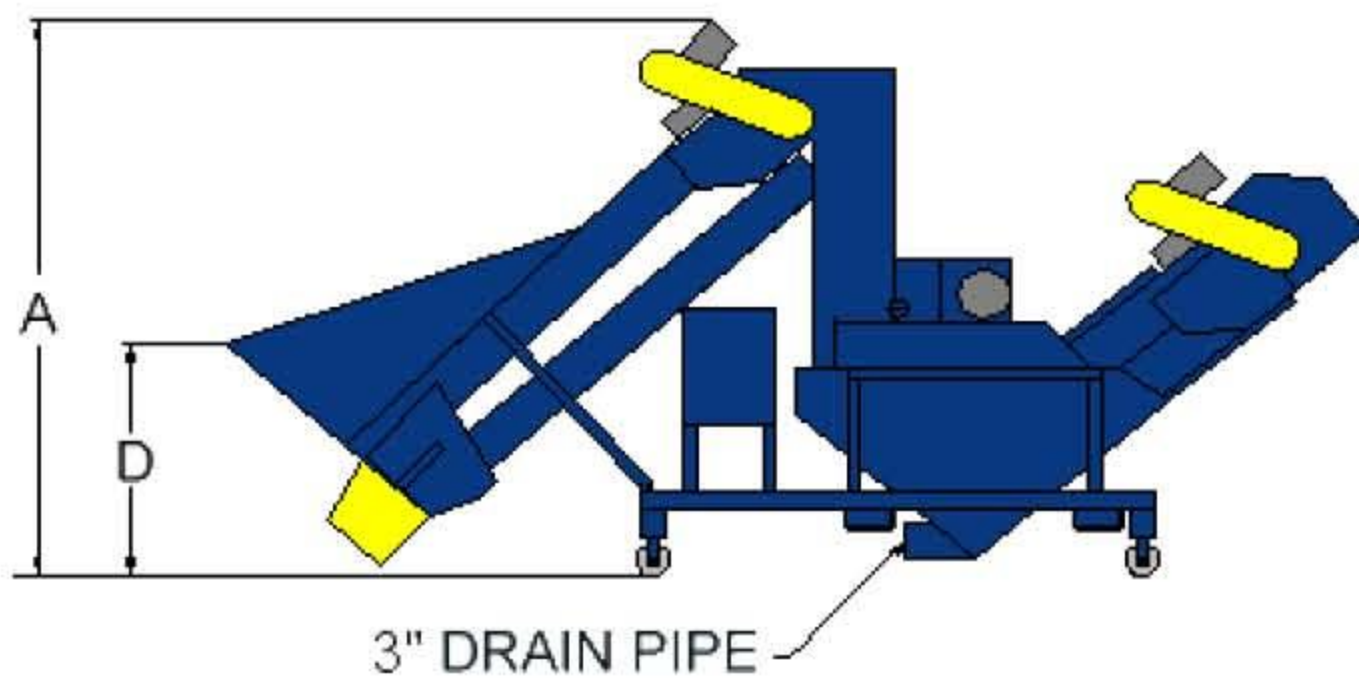

Features:

- Second generation field-proven design for high volume, low maintenance, and easy service
- Enclosed tail pulley cover with external take-ups for correct belt tracking and tension
- Low in-feed hopper for easy loading/visual inspection
- Enclosed belt and chain guards for user protection
- Fresh water rinse on out feed conveyor
- Processes up to 600 cases of aluminum cans or up to 3000 PET bottles per hour.

Specifications:

- All steel unitized construction
- PVC-150 conveyor belting with vulcanized cleats and Flexco 125 Megalloy Lacing
- 8" diameter head pulley, and 6" diameter crowned tail pulley
- 6" industrial steel casters
- Enclosed sides and bottom of belt return pan
- 1/2 HP TEFC conveyor motor
- 5 HP TEFC crusher motor

Electrical safety features:

- 240/480 volt, three phase
- Electrical components are UL listed
- NEMA-4 (hose proof) enclosure
- Sequential manual start motor controls
- Main safety fused disconnect
- Individual motor overload/short circuit protection
- Safety interlock on crusher access door

Dimensions:	CC-5B	CC-5B Perf
Height (A)	8' 4"	8' 4"
Length (B)	16'	16'
Width (C)	3' 8"	4' 2"
Loading height (D)	3' 4"	3' 7"
Weight approx. (lbs.)	2100	2275
Hopper:		
Capacity (in 16")	1/3 cu. Yd.	2/3 cu. Yd.
Conveyor:		
Discharge height	4' 5"	4' 5"
Belt width	16"	24"
Cleat size	1-1/2"	3"
Crushing drum:		
CC-5B	16" wide welded steel cleats	
CC-5B PERF	24" wide welded steel teeth	
Density:		
CC-5B	5-6lbs. Per cu./ft. (Aluminum cans)	
CC-5B PERF	35-50% Size reduction on PET Containers 2-4 lbs. Per cu./ft. (Aluminum cans)	

Options:

- 240 volt, single phase
- Stainless steel upgrade
- 208, 380, 415, 480, or 575 volt, three phase
- Power cord
- Custom conveyors, hoppers, discharge heights
- Pump for fluid capture tank
- Wash-down duty bearings
- If you don't see it, ask us!

LIMITED ONE YEAR WARRANTY

*All dimensions are nominal +/- 1"

*Specifications subject to change without notice, without incurring responsibility to previous units sold



Recycling Equipment Corporation
831 West 5th Street
Lansdale, PA 19446
Phone 267-218-7200
Fax 267-218-7215